

THE PLANETARY ROVERS

(Space Exploration Vehicle)

By: Mr. Rohit Raju Nikam.

B-Tech Mechanical Engineer,

MIT-ADT University's School of Engineering, Pune.

E-Mail: nikamrohit082@gmail.com

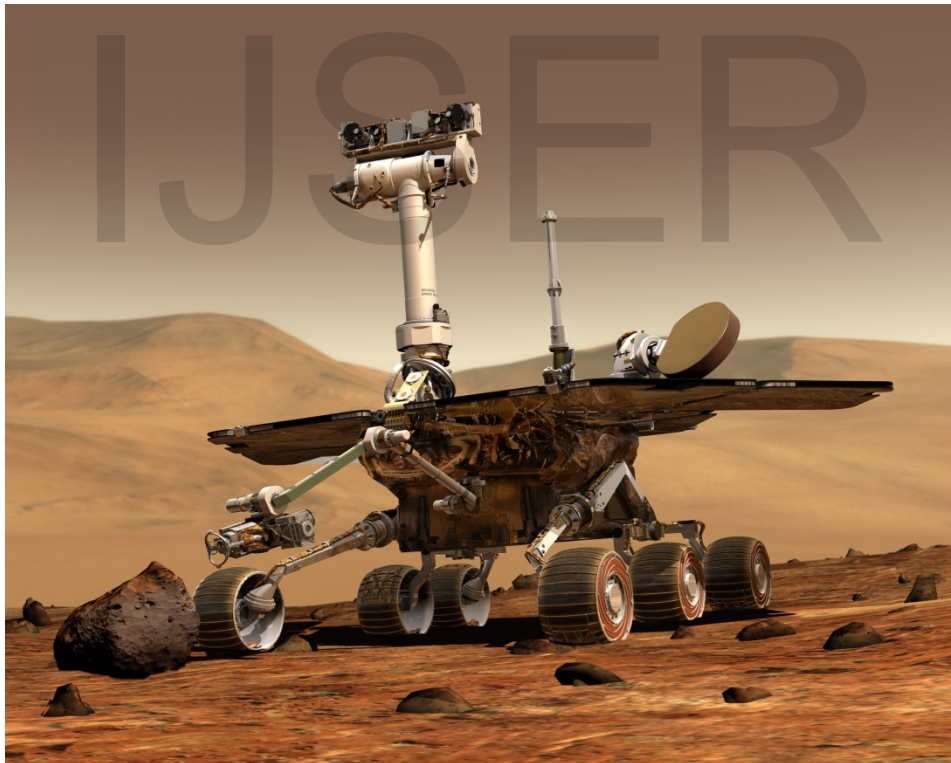

Abstract

For the investigation of planetary surfaces emphasises their central importance in space exploration. This imposes a completely new set of technologies and methodologies to the design of such spacecraft and planetary rovers are indeed, first and foremost, spacecraft. This introduces vehicle engineering, mechatronics, robotics, artificial intelligence and associated technologies to the spacecraft engineer's repertoire of skills. A rover (or sometimes planetary rover) is a space exploration vehicle designed to move across the surface of a planet or other celestial body. Some rovers have been designed to transport members of a human spaceflight crew; others have been partially or fully autonomous robots. In this paper we summarize the design, development and types of rovers.

Key Words: Space exploration, Spacecraft, Robotics.

Objectives

- To understand the concept of planetary rovers, (i.e. Space exploration vehicle)
- Familiarize yourself with types of Rovers
- To know the working of Rovers

IJSER

1. INTRODUCTION

A rover is a space exploration vehicle designed to move across the surface of a planet or other celestial body. Some rovers have been designed to transport members of a human spaceflight crew; others have been partially or fully autonomous robots. Rovers usually arrive at the planetary surface on a lander-style spacecraft. Rovers are created to land on another planet, besides Earth, to find out information and to take samples. They can collect dust, rocks, and even take pictures. They are very useful for exploring the universe.

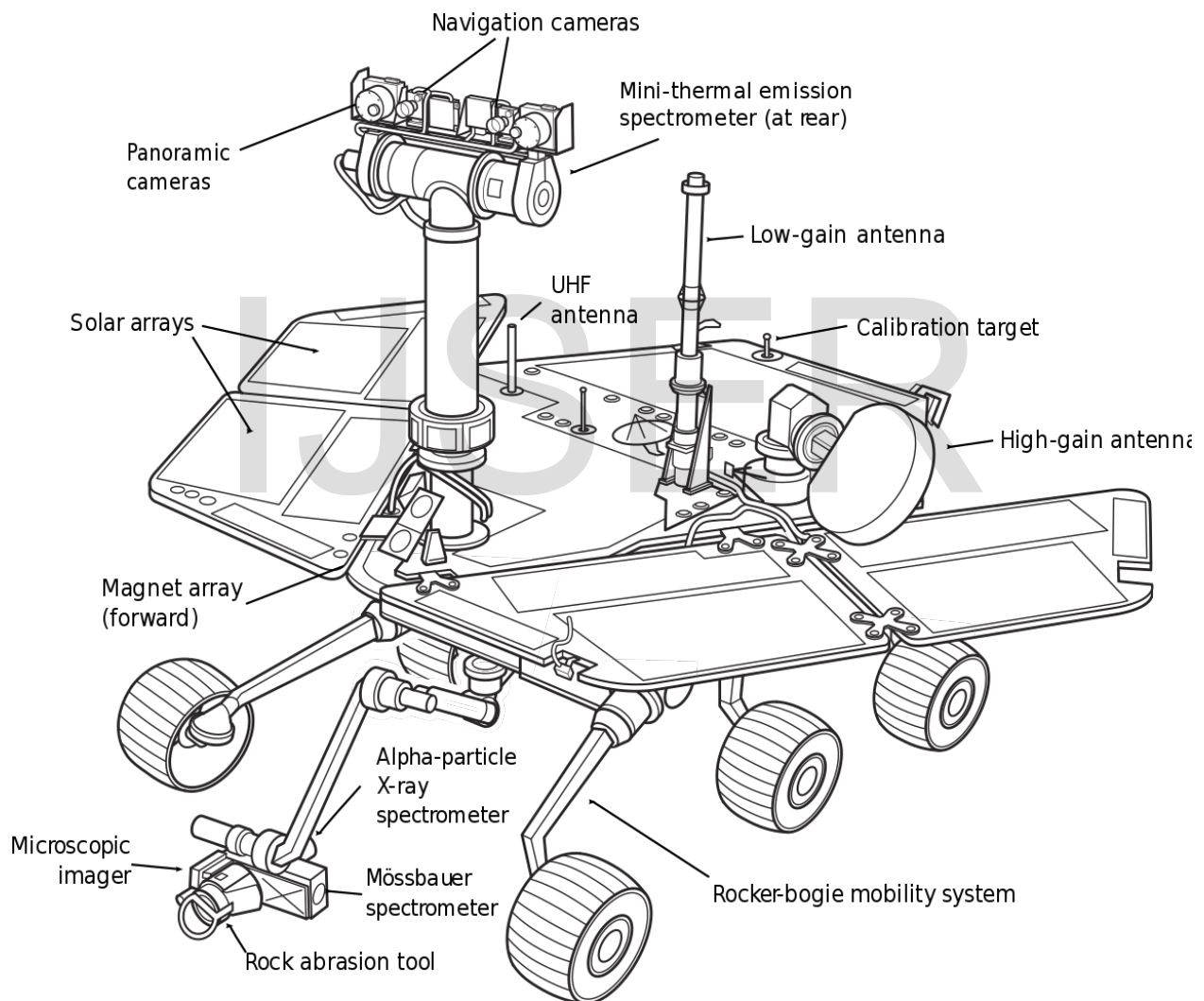

Fig.1.1.Planetary rover Configuration

Features

i. Autonomy

Rovers which land on celestial bodies far from the Earth, such as the Mars Exploration Rovers, cannot be remotely controlled in real-time since the speed at which radio signals travel is far too slow for real time or near-real time communication. For example, sending a signal from Mars to Earth takes up to 3 to 20 Mini. These rovers are thus capable of operating autonomously with little assistance from ground control as far as navigation and data acquisition are concerned, although they still require human input for identifying promising targets in the distance to which to drive, and determining how to position itself to maximize solar energy. Giving a rover some rudimentary visual identification capabilities to make simple distinctions can allow engineers to speed up the reconnaissance. During the NASA Sample Return Robot Centennial Challenge, a rover, named Cataglyphis, successfully demonstrated autonomous navigation, decision-making, and sample detection, retrieval, and return capabilities.

ii. Compactness

Rovers are usually packed for placing in a spacecraft, because it has limited capacity, and have to be deployed. They are also attached to a spacecraft, so devices for removing these connections are installed.

iii. Reliability

Rovers have to withstand high levels of acceleration, high and low temperatures, pressure, dust, corrosion, cosmic rays, remaining functional without repair for a needed period of time.

iv. Non-wheel approaches

Other rover designs that do not use wheeled approaches are possible. Mechanisms that utilize "walking" on robotic legs, hopping, rolling, etc. are possible. For example, Stanford University researchers have proposed "Hedgehog", a small cube-shaped rover that can controllably hope or even spin out of a sandy sinkhole by corkscrewing upward to escape for surface exploration of low gravity celestial bodies.

2. History of the Rovers exploring the planets

a. LUNOKHOD

Two Soviet mobile vehicles, the Lunokhods, have landed on the Moon, one in November 1970 and the other in January, 1973. The Lunokhods were remotely controlled roving vehicles that carried television cameras and instruments to measure the physical and chemical properties of the lunar soil.

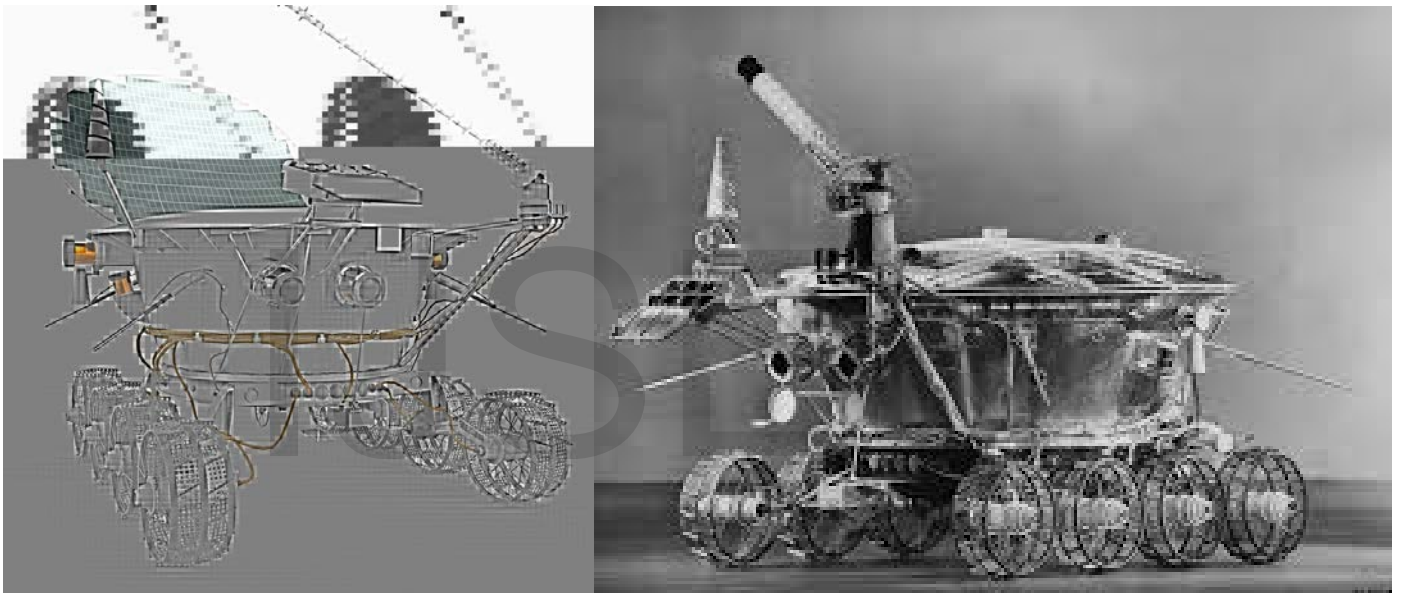

Fig.2.1.Lunokhod the Space robot

b. Apollo

NASA included Lunar Roving Vehicles in three Apollo missions: Apollo 15 (which landed on the Moon July 30, 1971), Apollo 16 (which landed April 21, 1972) and Apollo 17 (which landed December 11, 1972). The six Apollo lunar landing missions demonstrated the value of manned exploration of planetary surfaces. The astronauts were able to set up scientific instruments, choose the most interesting samples for collection, and study the geology of the lunar surface.

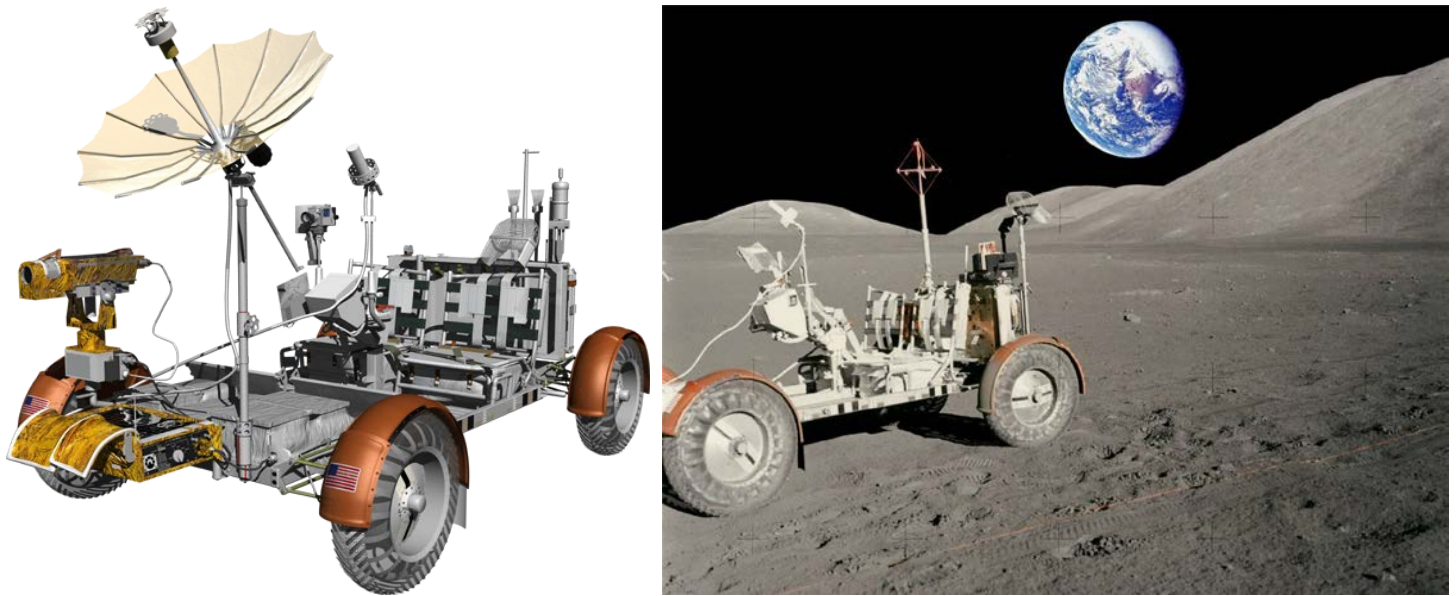

Fig.2.1.Apollo lunar rover

3. Mars Exploration Rover

NASA's Mars Exploration Rover (MER) mission is an ongoing robotic space mission involving two Mars rovers, Spirit and Opportunity, exploring the planet Mars. It began in 2003 with the launch of the two rovers: MER-A Spirit and MER-B Opportunity—to explore the Martian surface and geology; both landed on Mars at separate locations in January 2004. Both rovers far outlived their planned missions of 90 Martian solar days: MER-A Spirit was active until 2010, while MER-B Opportunity is still active in 2018, and holds the record for the longest distance driven by any off-Earth wheeled vehicle

Objective of Mars Mission

- Search for and characterize a variety of rocks and soils that hold clues to past water activity. In particular, samples sought include those that have minerals deposited by water-related processes such as precipitation, evaporation, sedimentary cementation, or hydrothermal activity.
- Determine the distribution and composition of minerals, rocks, and soils surrounding the landing sites.
- Determine what geologic processes have shaped the local terrain and influenced the chemistry. Such processes could include water or wind erosion, sedimentation, hydrothermal mechanisms, volcanism, and cratering.

- Perform calibration and validation of surface observations made by Mars Reconnaissance Orbiter instruments. This will help determine the accuracy and effectiveness of various instruments that survey Martian geology from orbit.
- Search for iron-containing minerals, and to identify and quantify relative amounts of specific mineral types that contain water or were formed in water, such as iron-bearing carbonates.
- Characterize the mineralogy and textures of rocks and soils to determine the processes that created them.
- Search for geological clues to the environmental conditions that existed when liquid water was present.
- Assess whether those environments were conducive to life.

Space Craft Design

The Mars Exploration Rover was designed to be stowed in the nose of a Delta II rocket. Each spacecraft consists of several components:

- Rover: 185 kg (408 lb.)
- Lander: 348 kg (767 lb.)
- Back shell / Parachute: 209 kg (461 lb.)
- Heat Shield: 78 kg (172 lb.)
- Cruise Stage: 193 kg (425 lb.)
- Propellant: 50 kg (110 lb.)
- Instruments: 5 kg (11 lb.)

Total mass is 1,063 kg (2,344 lb.).

The cruise stage is the component of the spacecraft that is used for travel from Earth to Mars. It is very similar to the Mars Pathfinder in design and is approximately 2.65 meters (8.7 ft.) in diameter and 1.6 m (5.2 ft.) tall, including the entry vehicle (see below).

The primary structure is aluminum with an outer ring of ribs covered by the solar panels, which are about 2.65 m (8.7 ft.) in diameter. Divided into five sections, the solar arrays can provide up to 600 watts of power near Earth and 300 W at Mars.

Heaters and multi-layer insulation keep the electronics "warm". A Freon system removes heat from the flight computer and communications hardware inside the rover so they do not overheat. Cruise avionics systems allow the flight computer to interface with other electronics, such as the sun sensors, star scanner and heaters.

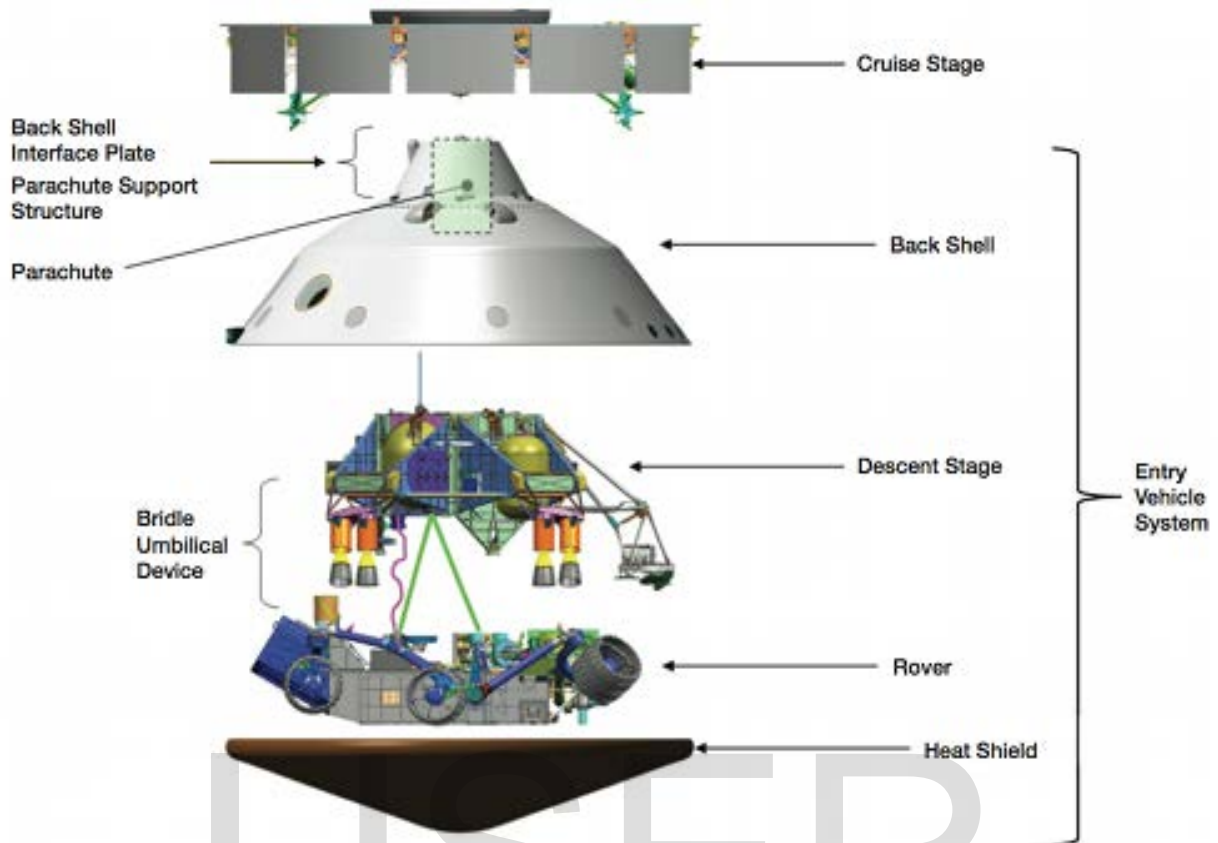

Fig.3.1.Components of space craft

Rover Design

The rovers are six-wheeled, solar-powered robots that stand 1.5 m (4.9 ft.) high, 2.3 m (7.5 ft.) wide and 1.6 m (5.2 ft.) long. They weigh 180 kg (400 lb.), 35 kg (77 lb.) of which is the wheel and suspension system.

o Drive system

Each rover has six wheels mounted on a rocker-bogie suspension system that ensures wheels remain on the ground while driving over rough terrain. The design reduces the range of motion of the rover body by half, and allows the rover to go over obstacles or through holes that are more than a wheel diameter (250 millimeters (9.8 in)) in size. The rover wheels are designed with integral compliant flexures which provide shock absorption during movement. Additionally, the wheels have cleats which provide grip for climbing in soft sand and scrambling over rocks.

Each wheel has its own drive motor. The two front and two rear wheels each have individual steering motors. This allows the vehicle to turn in place, a full revolution, and to swerve and curve, making arching turns. The rover is designed to withstand a tilt of 45 degrees in any direction without overturning. However, the rover is programmed through its "fault protection limits" in its hazard avoidance software to avoid exceeding tilts of 30 degrees.

Each rover can spin one of its front wheels in place to grind deep into the terrain. It is to remain motionless while the digging wheel is spinning. The rovers have a top speed on flat hard ground of 50 mm/s (2 in/s). The average speed is 10 mm/s, because its hazard avoidance software causes it to stop every 10 seconds for 20 seconds to observe and understand the terrain into which it has driven

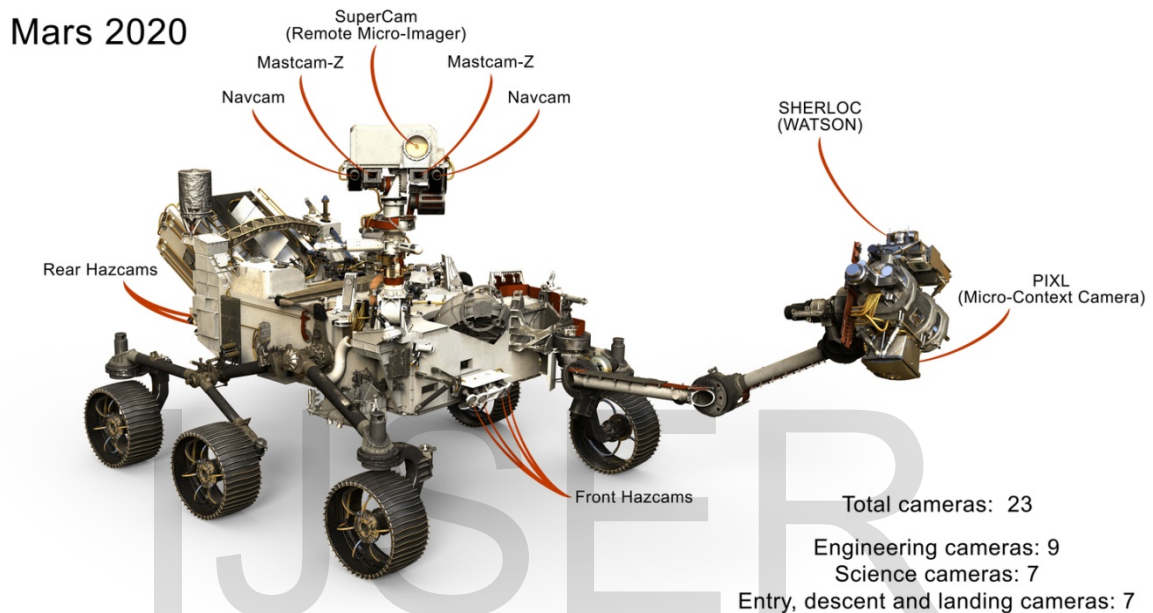

Fig.3.2.Mars Rover

○ Power and Electronic system

When fully illuminated, the rover triple junction. Solar arrays generate about 140 watts for up to four hours per Martian day (sol). The rover needs about 100 watts to drive. Its power system includes two rechargeable lithium ion batteries weighing 7.15 kg (15.8 lb.) each that provide energy when the sun is not shining, especially at night. Over time, the batteries will degrade and will not be able to recharge to full capacity.

For comparison, the Mars Science Laboratory's power system is composed of a Multi-Mission Radioisotope Thermoelectric Generator (MMRTG) produced by Boeing. The MMRTG is designed to provide 125W of electrical power at the start of the mission, falling to 100W after 14 years of service. It is used to power the MSL's many systems and instruments. Solar panels were also considered for the MSL, but RTGs provide constant power, regardless of the time of day, and thus the versatility to work in dark environments and high latitudes where solar energy is not readily available. The MSL generates 2.5 kilowatt hours per day, compared to the Mars Exploration Rovers, which can generate about 0.6 kilowatt hours per day.

○ Communication

The rover has an X band low-gain and an X band high-gain antenna for communications to and from the Earth, as well as an ultra high frequency monopole antenna for relay communications. The low-gain antenna is omnidirectional, and transmits data at a low rate to Deep Space Network (DSN) antennas on Earth. The high-gain antenna is directional and steerable, and can transmit data to Earth at a higher rate. The rovers use the UHF monopole and its CE505 radio to communicate with spacecraft orbiting Mars, the Mars Odyssey and (before its failure) the Mars Global Surveyor (already more than 7.6 terabits of data were transferred using its Mars Relay antenna and Mars Orbiter Camera's memory buffer of 12 MB).^[1] Since MRO went into orbit around Mars, the landers have also used it as a relay asset. Most of the lander data is relayed to Earth through Odyssey and MRO. The orbiters can receive rover signals at a much higher data rate than the Deep Space Network can, due to the much shorter distances from rover to orbiter. The orbiters then quickly relay the rover data to the Earth using their large and high-powered antennas.

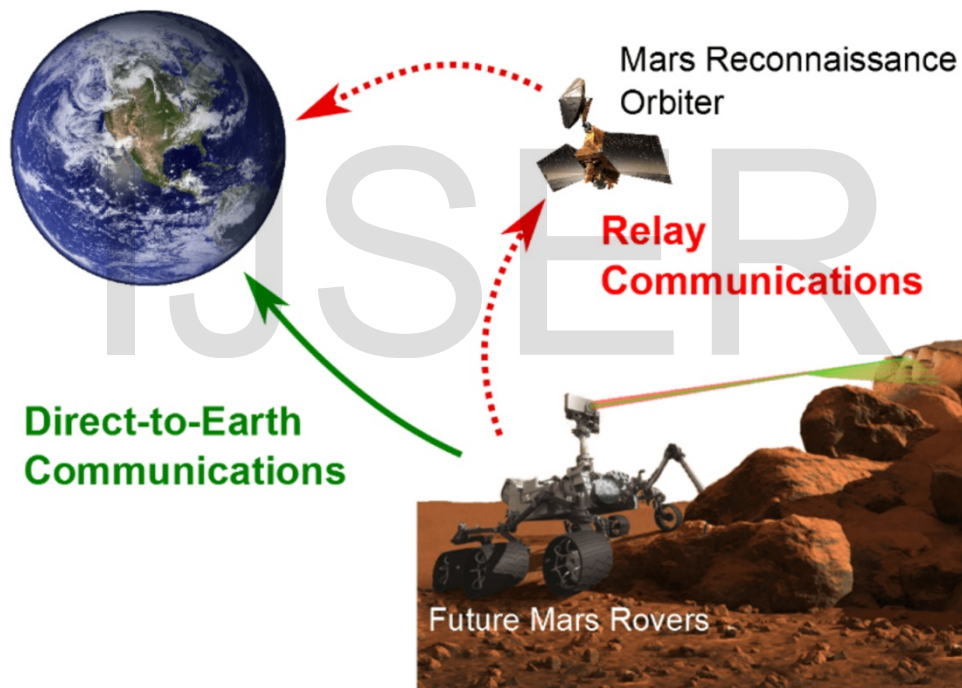

Fig.3.3.Relay communication of rover

○ Scientific Instrumentation

The rover has various instruments. Three are mounted on the Pancam Mast Assembly (PMA)

- Panoramic Cameras (Pancam), two cameras with color filter wheels for determining the texture, color, mineralogy, and structure of the local terrain.
- Navigation Cameras (NavCam) two cameras that have larger fields of view but lower resolution and are monochromatic, for navigation and driving.
- A periscope assembly for the Miniature Thermal Emission Spectrometer (Mini-TES), which identifies promising rocks and soils for closer examination, and determines the processes that formed them. The Mini-TES was built by Arizona State University. The periscope assembly features two beryllium fold mirrors, a shroud that closes to minimize dust contamination in the assembly, and stray-light rejection baffles that are strategically placed within the graphite epoxy tubes.

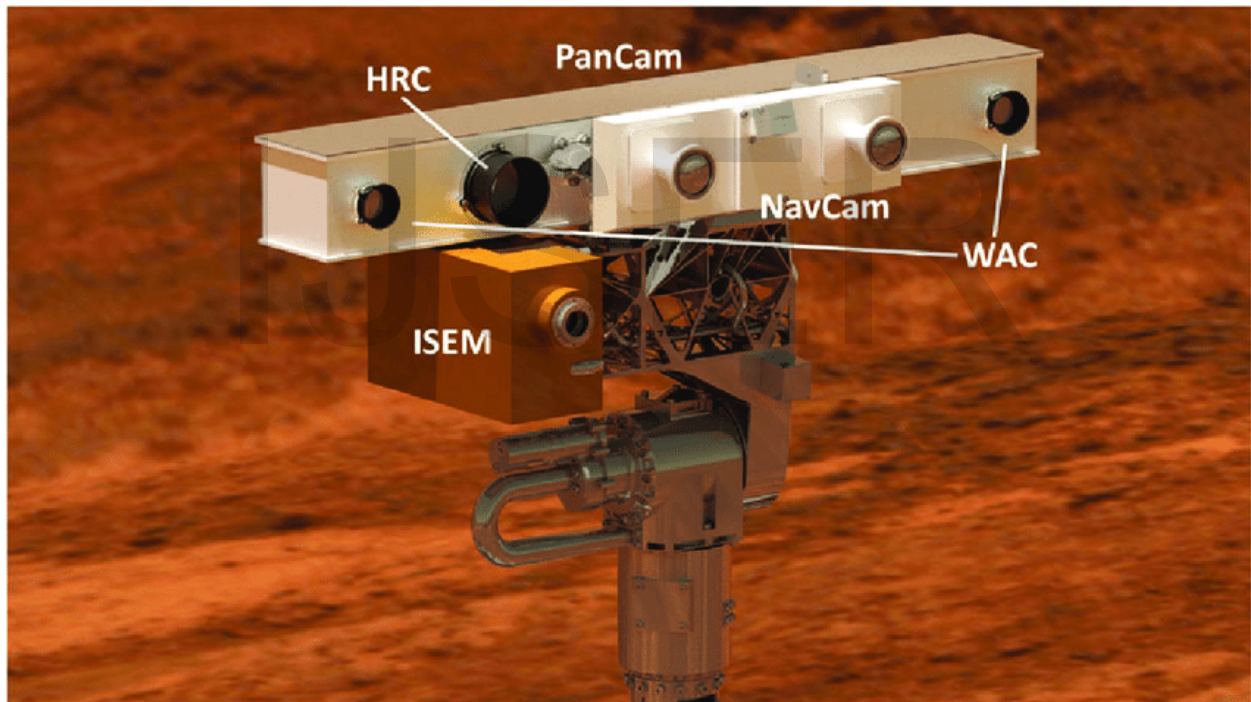
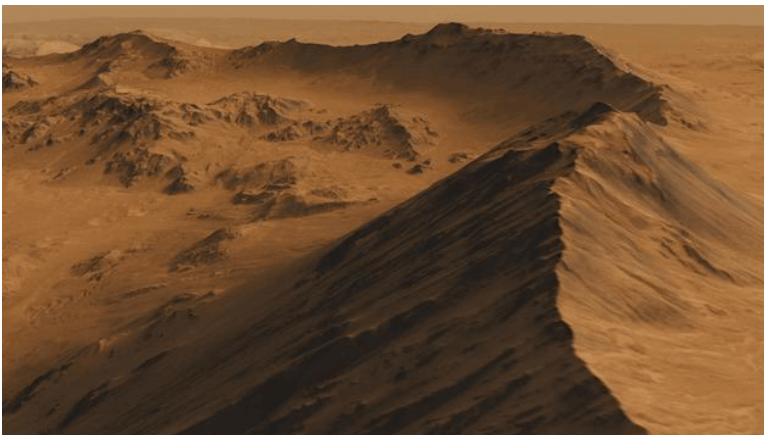
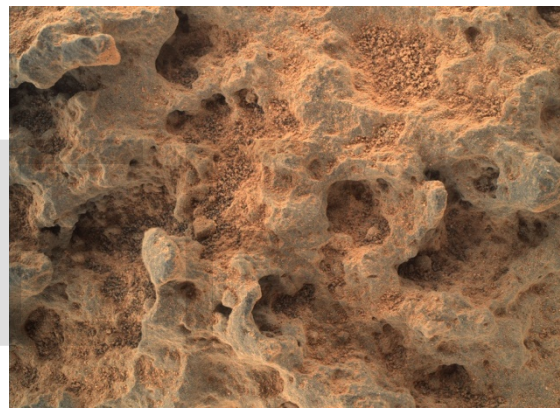
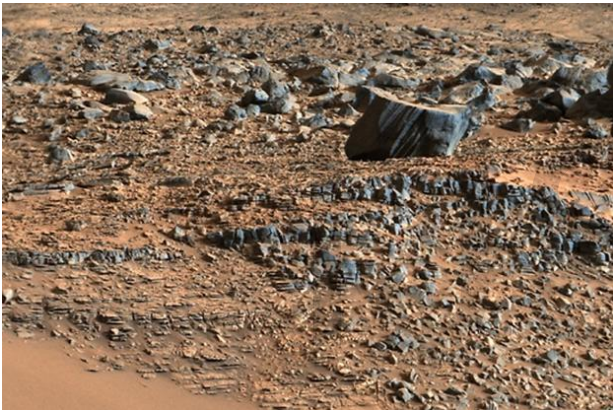
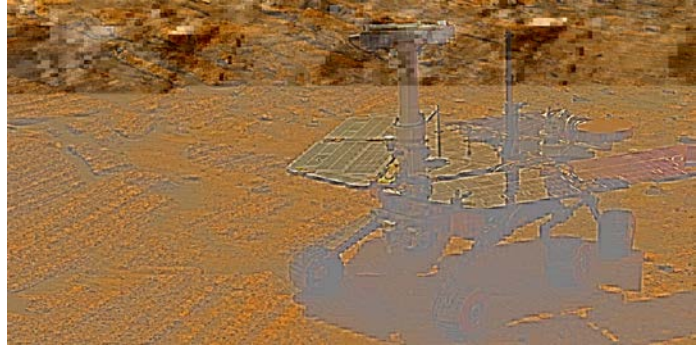
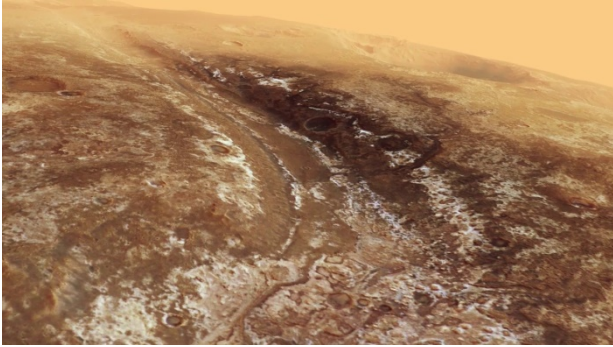

Fig.3.4.Rover scientific Instruments

PHOTOGRAPHS TAKEN BY MARCE ROVER



CONCLUSION

In this paper we define the development of Space Rovers, its various parts and their function. The Space Rover Program's storied history is vast and well documented. Understanding the design and operations of this unique and complex vehicle is not confined to the study of one program, but of many. It touches on only a handful of the lessons that were learned through the various supersonic and hypersonic research programs that laid the foundation for Rovers. The NASA tries to make highest technological robots which are landing on planets and will make the survey of it. It is owner to us that we are reaching to the planets.

IJSER

REFERENCES

- [1] G. Ishigami, A. Miwa, K. Yoshida, Steering Trajectory Analysis of Planetary Exploration Rovers Based on All-Wheel Dynamic Model, Proc. Of the 8th Int. Symp. on Artificial Intelligence, Robotics and Automation in Space, Munich, Sept. 2005.
- [2] G. Ishigami, A. Miwa, K. Nagtani, K. Yoshida, Terramechanics Based Model for Steering Maneuver of Planetary Exploration Rovers on Loose Soil, Journ. Of Field Robotics, vol. 24, n. 3, 2007, pp. 233-250.
- [3] K. Schilling, C. Jungius, Mobile Robots for Planetary Exploration, in A.Halme / K.Koskinen (eds.), Intelligent Autonomous Vehicles, pp.110-120, 1995.
- [4] N. Patel, G.P. Scott, A. Ellery, Application of Bekker Theory for Planetary Exploration through Wheeled, Tracked and Legged Vehicle Locomotion, AIAA 2004-6091, Space 2004 Conference and Exhibit, 28 - 30 September 2004, San Diego, California.
- [5] www.wikipedia.com

IJSER